



*Because Life is a Moving Experience™*



2008 & Up Chrysler  
Foldout Entervan®

*Operator's  
Manual*

## Congratulations

We at The Braun Corporation wish to express our fullest appreciation on your new purchase. With you in mind, our skilled craftsmen have designed and assembled the finest lowered floor vehicle available.

This manual includes safety precautions, operating instructions, manual operating instructions, and instructions for maintenance and lubrication procedures.

Your Entervan® is built for dependability, and will bring you years of pleasure and independence, as long as the maintenance is performed regularly and the Entervan® is operated by an instructed person.

Sincerely,

THE BRAUN CORPORATION



Ralph W. Braun  
Chief Executive Officer

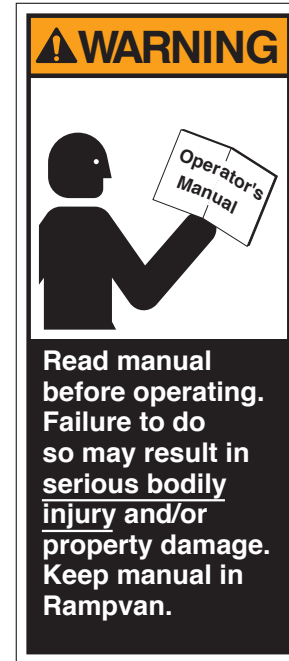

<b>Warranty and Registration</b>		
<b>Instructions</b> .....	2	
<b>Introduction</b> .....	3	
<b>Entervan Operation Quick Reference Guide</b> .....	4, 5	
<b>Features</b> .....	6, 7	
<b>Safety Precautions</b> .....	8	
<b>Operation</b>		
Terminology .....	9	
One-Touch Control System .....	9	
Control Switches .....	10-14	
Ramp Access Sliding Door .....	14, 15	
Kneel System .....	16, 17	
Power Ramp Operation .....	18	
Power Ramp Safety .....	19	
Power Ramp Manual Operation .....	20	
Ramp Electrical Override .....	21	
Ramp Safety .....	22-24	
<b>Wheelchair and Occupant Restraint</b> .....	25-33	
<b>Seat Removal and Installation</b>		
Front Seats (General Information) .....	34, 35	
Seat Base Rear Covers .....	35	
Seat Electrical Harnesses .....	37-39	
Front Seat Removal .....	40, 41	
Front Seat Installation .....	42, 43	
Third Row Seats .....	44, 45	
<b>Warranty</b> .....	46-49	
<b>Return Authorization Procedure</b> .....	49	
<b>Preventive Maintenance</b> .....	50, 51	
<b>Auxiliary Power Supply / Below Floor Obstructions</b> .....	52-55	
<b>Jacking and Tire Changing</b> .....	56	
<b>Reporting Safety Defects</b> .....	57	
<b>Towing</b> .....	58	

## WARRANTY AND REGISTRATION INSTRUCTIONS

Examine your Entervan® for any damage. Should any damage have occurred during delivery, notify the carrier at once with any claims.

The warranty/registration card shown here is supplied with each Entervan. Review the delivery checklist and fill out the warranty/registration information with your sales representative and mail it to The Braun Corporation®.

A detailed Warranty section is provided within this manual. The **warranty card must be processed to activate the warranty.**

Record the last eight digits of the vehicle identification number (VIN) in the space provided for future reference. **This information must be provided when filing a warranty claim or ordering parts.**

**BraunAbility**  
Because Life is a Moving Experience®

**Vehicle Delivery Checklist & Warranty Registration**

Customer Name \_\_\_\_\_ Web Referral Code \_\_\_\_\_  
Address \_\_\_\_\_ City \_\_\_\_\_ State \_\_\_\_\_ ZIP \_\_\_\_\_  
Phone \_\_\_\_\_ Email \_\_\_\_\_  
VIN \_\_\_\_\_ Date of Purchase \_\_\_\_/\_\_\_\_/\_\_\_\_  
Sales Person \_\_\_\_\_ City \_\_\_\_\_ State \_\_\_\_\_

**To be completed by Sales Consultant prior to Customer being present**

- Vehicle is equipped as indicated in the sales contract
- Vehicle serial number clean
- Delivery appointment verified (if applicable)
- Vehicle and customer paperwork prepared
- OEM and Braun owner's manuals and other materials in glove box

**To be reviewed and explained by Sales Consultant with Customer present**

**Pre-Delivery**

- Inspect exterior to ensure it's clean and damage free
- Verify tire and jack location
- Operation of remote control
- Diagnostic entry (if applicable)
- Exterior operation and activation of power door, kneeling and ramp
- Manual operation of door and ramp from exterior

**Interior**

- Handles and instrumentation
- Location of master controls to operate all-terrain features
- Manual operation of door and ramp from interior
- Operation of low-beam
- Operation of roll & stabilize seating (if applicable)
- Operation of seat belts
- Location of Braun computer

**Review both OEM and Braun owner's manuals**

- Explain the Toyota Service Exchange Information Program (Toyota Chassis Only)
- Explain recommended preventive maintenance and service schedule
- Inform Customer of delivery service fees
- Advise Customer to receive and maintain a signed receipt of all service work performed
- Complete and return warranty registration to activate warranty
- List all aftermarket equipment. Use brand names and model numbers where possible

Identify all hardware that the monthly check-up schedule to the vehicle has been discontinued for use, and fully document and no damage to the Braun Corporation, and its representatives, may be applied to the vehicle. A vehicle safety and recall program will be implemented. The Braun Corporation will be notified by the dealer, including all applicable, and the Braun Corporation will be notified of any applicable recall information. Use brand names and model numbers where possible.

**Customer:**  
I acknowledge that all items checked have been reviewed with me.

**Sales Consultant:**  
All items checked have been reviewed with the customer.

Customer Signature / Date \_\_\_\_\_  
Sales Consultant Signature / Date \_\_\_\_\_

Please FAX completed form to 1-800-946-6305 • P.O. Box 310 • Wilmunc, IN 46996 • [info@braunability.com](mailto:info@braunability.com) • 34350 • 2108

Vehicle Identification Number (VIN) \_\_\_\_\_

The Braun Entervan® lowered floor conversion is designed to provide years of pleasure and mobility independence. Familiarity with proper operation and maintenance procedures will help ensure safe, trouble free operation.

The Braun Corporation encourages wheelchair passengers and their attendant(s) to review the material contained in this manual with your Entervan sales representative, **before attempting operation**. Any questions or concerns can be answered by your sales representative at that time.

This manual addresses Entervan standard features as well as options. Refer to the instructions applicable for your package, and disregard the information that does not apply. Contact The

Braun Corporation at 1-800-THE LIFT® if any of this information is not understood.

The Entervan® Operation Quick Reference Guide hanging on the mirror provides a condensed explanation of Entervan operation (shown at right). Read the guide and then insert it in this manual for future reference. **Note:** An Operation Quick Reference Guide (overview) section is provided on pages 4 and 5 of this manual also.

Store this manual in the vehicle along with your Chrysler owner's manual.

If you experience an operation problem or there is any sign of wear, damage, or other abnormal condition, contact your sales representative or call The Braun Cor-

poration at 1-800-THE LIFT®. One of our national Product Support representatives will direct you to a Braun authorized service center.



Operation Quick Reference Guide

## ENTERVAN OPERATION QUICK REFERENCE GUIDE

### Entervan Operation Overview

This overview provides a simplified explanation of Entervan operation. Read the entire owner's (operator's) manual for complete details. Contact The Braun Corporation at 1-800-THE LIFT® if any of this information is not understood.

### Power Operation

Entervan power functions are managed by the electronic control system. The control system can be activated using the OEM remote keyless entry transmitter or one of the interior control switches detailed on pages 10-13.



OEM Remote  
Keyless Entry  
Transmitter

**Press and  
release** this  
switch two  
times (\*2)



Interior mounted control switches display one of these graphics.



or



### One-Touch Control Activation

Entervan power door, kneel and ramp functions are activated by **pressing and releasing** a control switch (press and release remote entry transmitter button twice).

**Open Functions:** When activating the Open functions, the power door opens, the kneel system lowers the rear of the vehicle and the ramp deploys.

**Close Functions:** When activating the Close functions, the ramp stows, the kneel system raises the rear of the vehicle and the power door closes.

### Manual Operation

The passenger side power sliding door and power ramp can be manually operated. Read this manual for further details.

**Operating Your New  
EnterVan Couldn't  
Be Simpler . . .**



**1** Just press any one of the buttons like the one pictured above or those shown on page 4 (press twice on the key transmitter) . . .

**2** And the sliding door opens

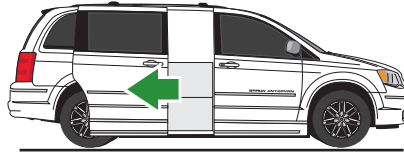

**3** The rear suspension lowers

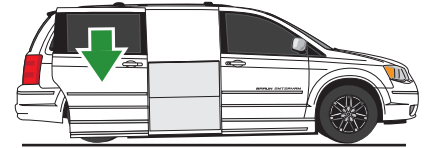

**4** The ramp deploys

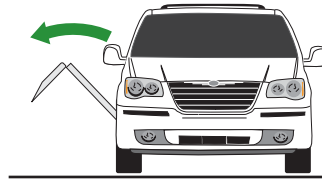

Allowing easy entrance!

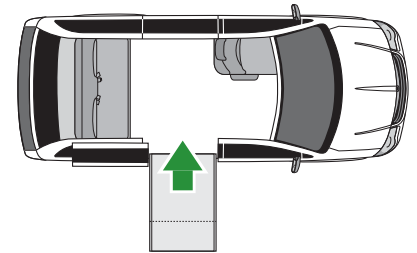

## FEATURES

**One-Touch Electronic Control System:** The electronic control system provides simple one-touch activation of Enter-van power functions. For your convenience, the power features can be activated using the OEM remote keyless entry transmitter or one of the interior switches detailed on pages 10-13.

**Passenger Side Power Slide Door:** The electronic control system activates the passenger side power slide door for ramp access. The slide door and lowered floor configuration provides 52-1/2" clear vertical passageway. **Note:** The driver-side sliding door is lowered to provide clear passage also.

**Ramp:** The fully automatic

power ramp provides 29-1/4" usable width. The power ramp can be manually operated.

**Electromechanical Power Kneeling Rear Suspension:** "Kneeling" is the lowering motion of the electromechanical rear suspension. The kneel feature reduces the slope of the ramp when deployed.

**Lowered Floor from Rear Axle to Firewall:** This feature provides additional headroom (57-1/4" floor-to-ceiling at center of van), and further reduces the slope of the ramp when deployed. **Note:** The floor-to-ceiling height is reduced by 2-1/2" with OEM interior DVD/rail system installed. **Ground Clearance:** The lowered floor

results in reduced ground clearance. Be aware of limited ground clearance.

**Ground Effects:** Exterior color-matched ground effect panels conceal the lowered floor and lowered sliding doors.

**Floor Track for Wheelchair and Occupant Securement in Midpoint Lowered Floor Area:** Floor track provided in the midpoint lowered floor area (Position C) can be utilized for restraint of wheelchair passenger(s). Wheelchair capacity at midpoint may have limitations based on the dimensions of specific wheelchairs.

**Forward-Facing Wheelchair and Occupant Belt/Track System:** One Forward-Facing



Wheelchair and Occupant Belt Kit is supplied for the restraint of one wheelchair and occupant. The belt kit is used in conjunction with the floor track. **Note:** Additional belt kits can be purchased (option).

**Quick-Release Front Passenger Seat with Floor Track for Wheelchair and Occupant Securement:** The passenger seat (Position **B**) is equipped with “step & roll” quick-release seat base attachments (making seat removal and installation procedures simple). The seat can be removed and the seat location can be utilized by a wheelchair occupant (floor track provided).

**Driver Seat:** For the wheelchair occupant who chooses to drive,

this seat (Position **A**) can be removed and adaptive driving systems custom tailored for the individual can be purchased from and installed by your local mobility dealer. The driver’s seat is equipped with “step & roll” quick-release seat base attachments. 56-1/4" floor-to-ceiling headroom is provided at both front seating positions.

**Auxiliary Power Supply for Dealer-Installed Power Seat or Electric Tie-Downs:** This power source is available to accommodate adaptive driving systems custom tailored for the individual (purchased from and installed by your local mobility sales representative). See pages 52-55.

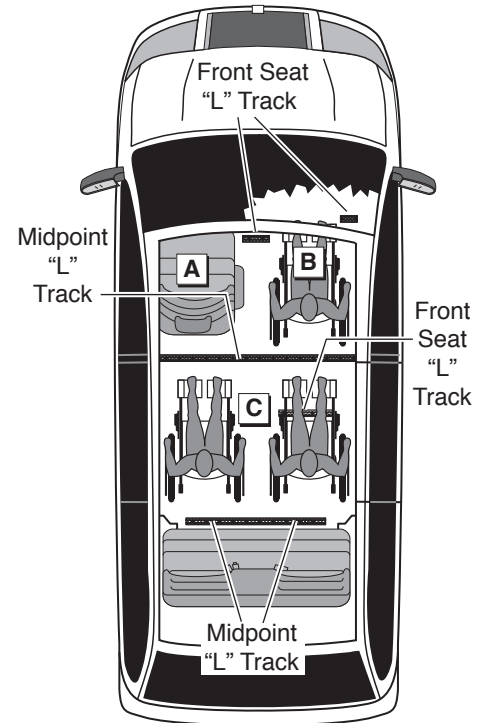

Available Wheelchair Positions

## SAFETY PRECAUTIONS

### Safety Symbols

#### SAFETY FIRST! Know That....

**A** All information contained in this manual and supplements (if included), is provided for your safety. Familiarity with proper operation instructions as well as proper maintenance procedures are necessary to ensure safe, trouble free operation. Safety precautions are provided to identify potentially hazardous situations and provide instruction on how to avoid them.

**B**



**C**

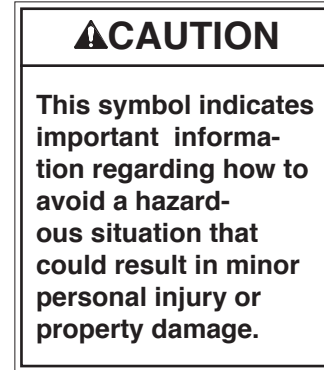

**D Note:** Additional information provided to help clarify or detail a specific subject.

These symbols will appear throughout this manual and may appear on labels posted on your Entervan.  
**Recognize the seriousness of this information.**

Whenever parking your Entervan and before utilizing Entervan power features, always engage the vehicle transmission in Park “P” and engage the vehicle parking brake. Entervan power function control switches can be activated **only** if the vehicle transmission is in Park or Neutral.

### Terminology

“Kneeling” is the lowering motion of the Entervan electromechanical rear suspension. The term “deploy” (unfold) indicates the lowering motion of the ramp to the deployed position. “Stow” (fold) is the raising motion of the ramp to the vertical (stowed) position.

The terms “Open” and “Close” refer to sequences of power functions that will occur when activated by the One-Touch electronic control system. When activating the Open functions, the power door opens, the kneel system lowers the rear of the vehicle and the ramp deploys. When activating Close functions, the ramp stows, the kneel system raises the rear of the vehicle and the power door closes.

### One-Touch Control System

Entervan power functions are managed by the electronic control system. The control system can be activated using the remote keyless entry transmitter or any one of the controls addressed on pages 10-13.

**Do not** attempt to interface aftermarket control systems.

#### **Braun Corporation Aftermarket Control Systems Policy:**

The Braun Corporation manufactures dedicated control systems for its products. These control systems have been designed and tested for use in conjunction with specific Braun products. Braun control systems are the **only** control systems authorized for use with Braun products.

**Do not** attempt to interface aftermarket control systems without authorization from The Braun Corporation. **To do so may result in serious bodily injury and/or property damage.**

### Control Switches

For your convenience, Entervan power features can be activated using the OEM remote keyless entry transmitter or one of the interior control switches identified on pages 11-13.

The passenger power sliding door switches provided on the remote keyless entry transmitter and in the overhead console will unlock the passenger side slide door and activate the Entervan power door, kneel and ramp functions.

The power sliding door switches provided in the center console and on the wall panels to the front and rear of the passenger side sliding door (B-pillar and C-pillar respectively), are accessible to rear seat passengers including small children. These control switches

will activate Entervan power functions **only** if the passenger side power slide door is unlocked and the overhead console Master Lock Out switch is in the ON position. Master Lock Out details are provided on page 13.

Braun minivan conversions are designed with safety and simplicity in mind for ease of operation. If a power function has been activated that was not intended, simply press a control switch to stop or reverse the function. If the desired function has not been activated, press the switch again.

Entervan power function control switches can be activated **only** if the vehicle transmission is in Park or Neutral.

#### Control Switches

Switches that activate Entervan power functions **at all times**:

- Keyless Entry Transmitter
- Overhead Console Passenger Power Sliding Door Switch

- 
- All Other Switches

The passenger side power slide door **must be unlocked** and the Master Lock Out switch **must be** in the **ON** position **before** power functions can be activated.

**One-Touch Control Activation**

Entervan power door, kneel and ramp functions will be activated by **pressing and releasing** either control switch shown on this page. Press and release the remote entry transmitter button twice within five seconds.

**Power Sliding Door Lock and Master Lock Out**

The keyless entry and overhead console switches will activate Entervan power functions whether the passenger sliding door is locked or unlocked. The Master Lock Out switch does not prohibit use of these control switches.

**Remote Keyless Entry Transmitter**

Using the Chrysler remote entry transmitter eliminates the need for an additional remote control.



**Press and release** this switch twice (\*2)

Press and release switch twice (\*2) within five seconds.



**Overhead Console Switch**

A control switch is located on the overhead console.



**Press and release** this switch

Press and release switch displaying slide door graphic.



## OPERATION

### Power Sliding Door Lock and Master Lock Out

The passenger side power sliding door **must be unlocked** and the overhead console Master Lock Out switch **must be** in the **ON** position **before** the three power sliding door switches identified here can activate Entervan power functions.

### One-Touch Control Activation

When the above conditions are met - power door, kneel and ramp functions will be activated by **pressing and releasing** any of the control switches.

### Center Console Switch

For front seat passengers, a switch is located in the center console (dashboard).



**Press and release** this switch

Press and release  
switch displaying  
slide door graphic.



### B-Pillar Switch

A switch is located on the wall panel ahead of the passenger side door (B-Pillar).



**Press and release** this switch

Press and release  
switch displaying  
slide door graphic.



**C-Pillar Switch**

A switch is located on the wall panel behind the passenger slide door (C-Pillar).



**Press and release** this switch

Press and release switch displaying slide door graphic.



**Power Sliding Door Master Lock Out Switch**

The Master Lock Out switch is located in the overhead console. If the Master Lock Out switch is in the OFF position, this OEM feature will **disable** the three power sliding door switches identified at left. Press the switch to the ON position to enable the control switches.

Press switch to **ON** to **enable** control switches.



Press switch to **OFF** to **disable** control switches.

Press switch displaying this graphic.



## OPERATION

### Kneel On/Off Switch

The Kneel On/Off switch is located on the driver side of the center console. The Kneel On/Off switch turns the kneel system on and off **only**. See page 16 for further details.

Press this switch to **ON** to activate kneel feature.

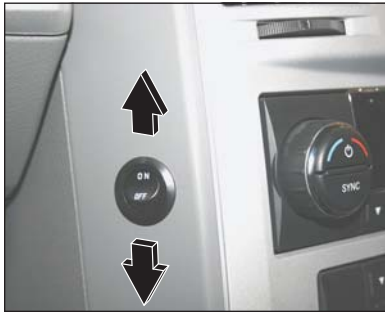

Press this switch to **OFF** to disable kneel feature.

### Ramp Access Sliding Door

Press and release the remote keyless entry transmitter or one of the interior control switches to activate the power sliding door (control switches detailed on pages 10-13). When a control switch is activated, the door will open and the Open sequence of functions will continue (rear of vehicle kneels and ramp deploys).

Once the Open sequence of functions is complete, press and release a control switch to close the door. The door will close after the ramp stows and the vehicle raises (completing the Close sequence of functions).

**Note:** If a control switch is activated while the power sliding door is opening or closing, the door will reverse direction.

**Note:** If the power door is obstructed while opening or closing, the door will reverse direction to the fully closed or fully open position, provided it meets sufficient resistance.

**Note:** If the inside or outside door handles are used while the power sliding door is activated, the power sliding door feature will be cancelled. Simply press a control switch and the door will open fully. The power door can also be opened or closed manually as detailed at right.



Keep clear of the area in which the power door operates. Ensure door travel path is clear. Personal injury or property damage may occur during power door operation. Be sure the door is fully closed and latched before driving.

**⚠ WARNING**

Keep clear of area in which power door operates. Failure to do so may result in bodily injury and/or property damage.

**Power Door Manual Operation**

The passenger side power sliding door can be operated manually. Unlock the passenger sliding door. Open the slide door from inside or outside using the OEM door handles. Always open the door smoothly. Avoid using excessive force when opening and closing the door.

**Note:** The ramp obstructs access to the inside door handle. The OEM handle has been equipped with an extension strap.

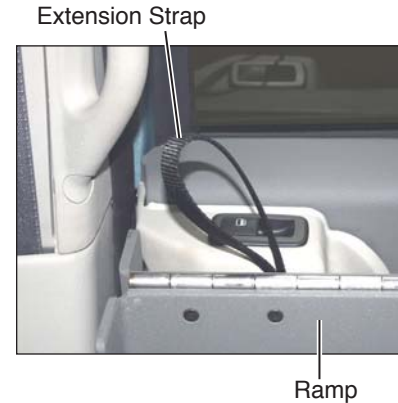

### Automatic Kneel System

Kneeling is the lowering motion of the Entervan electromechanical rear suspension. The kneel system lowers the rear of the vehicle. Lowering the rear of the vehicle reduces the slope of the ramp.

When the electronic control system is activated to start the Open functions, the kneel system starts to lower the rear of the vehicle at the same time the power sliding door starts to open. When the Close functions are activated, the rear of the vehicle starts to raise at the same time the ramp begins to stow.

### Kneel On/Off Feature

A Kneel On/Off feature is incorporated in the electronic control system. This feature provides the **option** of kneeling the vehicle when operating the power door and power ramp. The Kneel switch is located on the driver side of the center console (see page 14). The Kneel On/Off switch turns the kneel system on and off **only**. The Kneel switch must be in the On position in order for the kneeling system to be activated.

**Note:** If the Entervan is in the kneeled position and the Close functions are activated, the vehicle will raise whether the Kneel On/Off switch is On or Off.

**Note:** If the Kneel On/Off switch is switched from Off to On during the Open sequence of functions or within 60 seconds of ramp deployment, the vehicle will kneel after the ramp is fully deployed.

### Kneel On/Off Switch

Press this switch to **ON** to activate kneel feature.



Press this switch to **OFF** to disable kneel feature.

**Note:** If the Entervan is in the kneeled position (with ramp deployed) and the transmission is disengaged from Park “P,” the ramp will stow and the vehicle will raise.

**Note: Do not** leave your Entervan in the kneeled (lowered) position for extended periods of time. Doing so may result in battery drain.

In the event the kneel system is not functioning properly, have the kneel system repaired immediately. **Do not** drive with the rear of the vehicle in the lowered position. Attempting to do so will result in an extremely rough and unstable ride.

Contact your sales representative or call The Braun Corpora-

tion at 1-800-THE LIFT. One of our national Product Support representatives will direct you to an authorized service center.

### **Kneel Electrical Override**

An electrical override feature is incorporated in the kneel system. The override by-passes the electronic control system to electrically power the kneel actuator. The override is available to raise the rear of the vehicle only.

The Kneel Override Switch is located under the driver side rear bench seat. Press and hold the switch to release the kneel system (raise vehicle). Release the switch when the rear of the vehicle has raised fully. The kneel actuator motor will ratchet (make clicking sound).

Switch is located under driver side rear bench seat (viewed from rear with seat in raised position).



**Kneel  
Override  
Switch**

**Press and hold** this switch to release kneel (raise vehicle).

### Power Ramp Operation

The power ramp is activated by the electronic control system using any of the control switches identified on pages 11-13. When a control switch is activated to start the Open functions, the ramp deploys after the power sliding door reaches the fully open position. When the Close functions are activated, the ramp stow function begins immediately (simultaneously with the kneel system).

If a control switch is activated while the ramp is in motion (deploying or stowing), the ramp motor will stop running. Activating a control switch again will start the Close functions (ramp will stow, vehicle will raise and the door will close).

**Note:** The power sliding door must travel from the full closed position to the full open position in order for the ramp to deploy.

**Note:** If the vehicle transmission is disengaged from Park "P" while the ramp is deploying (in motion) or when the ramp is in the fully deployed position, the ramp will stow immediately.

**Note:** If the power ramp is obstructed while deploying or stowing, the ramp motor will stop running, provided it meets sufficient resistance. Press a control switch again and the ramp will stow and the door will close.

**Note:** When deploying the ramp, the ramp motor stops running when the ramp reaches the nearly horizontal position (approximately

6"- 8" above ground level). The ramp continues to slowly lower the remaining distance by the force of gravity.

**Forcing the Ramp:** Allow the power ramp to deploy (unfold and lower) fully before boarding the ramp. Forcing the ramp out or down during the deploy/stow functions, or boarding onto the ramp before it is fully-deployed **may result in damage** to the ramp, motor assembly and/or electronic controller.

### **CAUTION**

**Allow ramp to deploy fully before boarding. Failure to do so may result in damage.**

**Power Ramp Safety**

Be certain there is adequate clearance outside the Entervan before deploying the power ramp. Keep clear of area in which the ramp operates. Be certain no person or obstruction is within the path of the ramp when deploying or stowing the ramp. Keep clear of all power ramp moving parts. Do not attempt to grip or hold the ramp or ramp folding mechanism during operation.

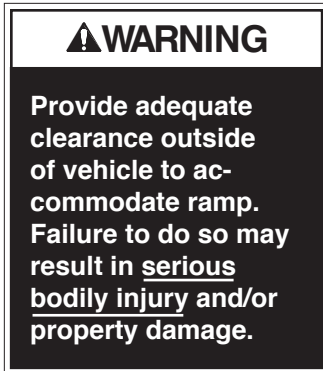

Keep body parts and obstructions clear of the area in which the ramp operates.

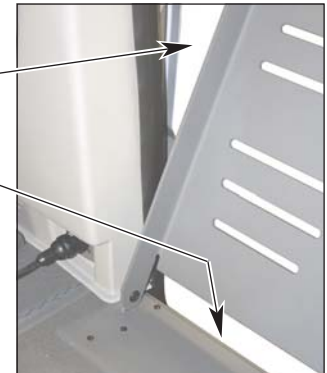

## OPERATION

### Power Ramp Manual Operation

The power ramp can be manually deployed and stowed. Ramp manual operation procedures must be performed by an assistant.

An oval-shaped HAND HOLD slot is provided on the ramp.

**Carefully** deploy and stow the ramp using the **HAND HOLD**.

The safety precautions addressed in the Power Ramp Safety section apply to manual ramp operation also. **Read and become familiar with all ramp safety precautions.**

Keep clear of the area in which the hinged ramp bi-fold extension folds and unfolds. Remember to use good body mechanics when

manually stowing and deploying the ramp.

Do not release the ramp when manually deploying or stowing the ramp. The ramp will free-fall.

Push the ramp out from inside the vehicle **only** if an assistant is not available and it is absolutely necessary (power failure). The ramp will free-fall.

Use **HAND HOLD** to **carefully** deploy and stow ramp.

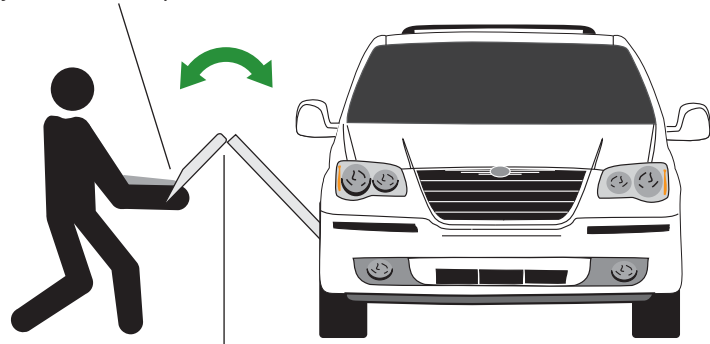

Keep clear of hinge area.

## Ramp Electrical Override

An electrical override feature is incorporated in the power ramp system. The override by-passes the electronic control system to electrically power the ramp. The override is available to stow (fold) the ramp only.

The Ramp Override Switch is located rear of the ramp in the lower wall panel. Press and hold the switch to stow (fold) the ramp. Release the switch when the ramp is fully stowed (stops).

**Caution:** If you stop pressing the override switch before the ramp is fully stowed, the **ramp may free-fall.**



**Ramp  
Override  
Switch**



**Press and hold** this switch to stow (fold) the ramp.

### Ramp Safety

Wheelchair passengers and attendants (when applicable), must use basic common sense and good judgment regarding ramp safety. Each wheelchair passenger has a unique set of physical abilities, combined with the physical characteristics of his or her wheelchair, that dictate the method in which he or she will enter and exit the Entervan. Consequently, the procedures for safe operation outlined in this manual are general in nature. Wheelchair attendants should be instructed on any special needs and/or procedures required for safe transport of wheelchair passengers.

Follow all safety instructions regarding torso restraints, stability, balance, weight distribution and use of attendants as specified in the owner's manual supplied with **your** wheelchair. Determine, establish and practice ramp boarding and exiting procedures under the direction of your health care professional, your wheelchair representative, and your Entervan sales representative to **ensure your ability to do so safely**.

Never board an Entervan ramp if you or your attendant are intoxicated. The wheelchair should be positioned in the center of the ramp at all times. You must be able to clearly view the ramp whenever boarding and exiting the vehicle. The wheelchair passenger and/or attendant must ensure the ramp is fully deployed before exiting the vehicle.

**It is the responsibility of the wheelchair operator to enter and exit the Entervan on the ramp in the safest manner.**

**Wheelchair-Equipped Occupant Seat Belts:** Wheelchair passengers should position and buckle their wheelchair-equipped seat belt (torso restraint),

### WARNING

**Position and fasten the wheelchair-equipped occupant seat belt before loading onto the wheelchair ramp. Failure to do so may result in serious bodily injury and/or property damage.**



as specified by the manufacturer, **before** loading onto a wheelchair ramp.

Different types of disabilities require different types of wheelchairs and different types of wheelchair-equipped occupant restraint belt systems (torso restraint).

It is the responsibility of the wheelchair passenger to have his or her wheelchair equipped with an occupant restraint (seat belt) under the direction of their health care professional.

**Stabilizing Wheelchairs:** Powered and manual wheelchairs are designed to remain upright and stable during normal operation. All activities which involve movement in a wheelchair have an effect on the combined center of gravity of the occupant and wheelchair. Be aware of the Entervan ramp slope (angle). The slope of the ramp has a direct effect on the center of gravity. Keep in mind your center of gravity and your ability to maintain stability and balance.



Do not operate your wheelchair on the Entervan ramp without assistance if you are unable to maintain stability and balance. Counterbalance devices (anti-tippers) may be available from your wheelchair representative to enhance stability and balance.

Do not tilt your wheelchair without assistance. Operate the wheelchair at a slow and constant speed when on the ramp. Do not accelerate suddenly when on the ramp. Do not raise the front wheelchair wheels (pull wheelie) when on the Entervan ramp.

## OPERATION

The aid of an attendant stabilizing the wheelchair is recommended for **optimum safety**. Wheelchair passengers who intend to enter and exit their Entervan without the assistance of an attendant must determine the safest and most practical method and orientation of entering and exiting the Entervan based on the physical characteristics of their personal wheelchair and his or her physical capabilities to maintain stability while the wheelchair is in motion on the Entervan ramp.

**Wheelchair Attendants:** When assisting a wheelchair occupant, remember to use good body mechanics. When the wheelchair is on the ramp, the attendant must grasp the push handles (or other) securely. Detachable wheelchair parts such as arms or leg rests must never be used for hand holds or lifting supports. Doing so could result in the detachable parts being inadvertently detached from the wheelchair **resulting in possible injury to the wheelchair occupant and/or the attendant.**

**Wheelchair Orientation and Securement During Transport:** The wheelchair and occupant **must** face the front of the vehicle and **must** be secured using the Forward-Facing Wheelchair and Occupant Belt and Track System when riding in the Entervan. See pages 25-33 for details.

One Forward-Facing Wheelchair and Occupant Belt Kit is supplied for the restraint of one wheelchair and occupant (details follow). “L-track” is mounted in four locations in the vehicle for belt securement (shown in Figure 1).

**Note:** Wheelchair passengers shown at right depict the available seating positions. Wheelchair capacity at Midpoint (Position C) may have limitations based on the physical dimensions of specific wheelchairs. Additional Forward-Facing Wheelchair and Occupant Belt Kits must be purchased for the restraint of each additional wheelchair passenger.

The Entervan offers the following options for placement and securement of wheelchair passengers.

**Driver Seat:** This seat (Position A) can be removed and adaptive driving systems custom tailored for the driving wheelchair occupant can be purchased from and installed by your local sales representative.

**Front Passenger Seat with Floor Track:** The passenger seat (Position B) can be removed and the seat location can be utilized by a wheelchair occupant.

**Midpoint Lowered Floor Area with Floor Track:** The Midpoint lowered floor area (Position C) can be utilized by wheelchair occupants (capacity limitations apply).

Refer to the following guidelines, illustrations, photos and instructions for proper use of the belt and track restraint system.

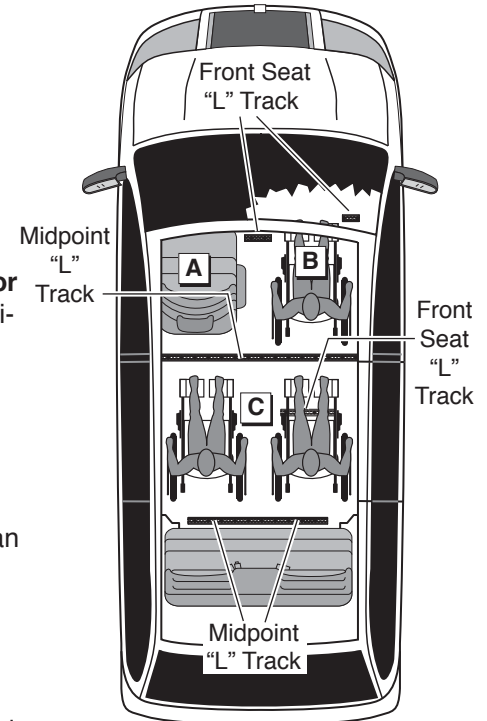

**Figure 1**

## WHEELCHAIR AND OCCUPANT RESTRAINT

### **⚠️ WARNING**

No product developed to date can guarantee successful securement of the wheelchair, even at low speeds, in the event of an accident. The Braun Wheelchair and Occupant Belt/Track System does meet the most widely referenced Federal Motor Vehicle Safety Standards used for contemporary restraint equipment. However, this equipment does not ensure stability of the wheelchair in the event of an accident at any speed.

**Wheelchair Securement:** Four adjustable over-center buckle belts are provided for securement of the wheelchair (two for the front and two for the rear).

The belts are equipped with one keeper fitting (attachment) which installs in the vehicle-mounted “L” track (details on pages 28 and 29). A hook is positioned on the opposite end of the belts for attachment to a solid frame member of the wheelchair. Do not attach belts to detachable wheelchair components such as armrests or leg rests. Front and rear belt tension is required.

Refer to the illustrations, photos and instructions on pages 28-33 for belt operation procedures.

Over-Center Belts  
(four supplied)



Lap Belt Extension  
(Midpoint)



Lap Belt Extension  
(Front Seats)



**Note:** Two lap belt extensions are supplied (as shown). Midpoint and front seat lap belt extensions are **not interchangeable**.

**Wheelchair Passenger Securement:** Two lap belt extensions are supplied for securement of the wheelchair occupant. The lap belt extensions are equipped with a keeper fitting (attachment) which installs in the vehicle-mounted “L” track. A female receptacle is positioned on the opposite end of the extension for attachment to a Chrysler factory-installed upper torso lap and shoulder belt.

**Note:** The midpoint lap belt extension is a standard belt style assembly (adjustable). The front seat extension is equipped with a rigid cable (nonadjustable). See photos on page 26. Lap belt extensions are **not interchangeable**. Attachment procedures are identical. See the illustrations on pages 30 and 31 and photos on page 33.

Operate the Chrysler lap and shoulder belt as instructed in your Chrysler owner’s manual. Follow all safety precautions. Connect the Chrysler lap and shoulder belt to the lap belt extension. Position the upper torso (shoulder) belt across the center of the shoulder. Position the lap belt low across the front of the pelvis (near hip). See the illustrations on pages 30 and 31 and photos on page 33.

Position of the lap belt buckle, after adjustment, is to be located near hip position. The belt is to be worn low and snugly. Adjustment of the lap belt extension is to be made at adjuster buckle. Wheelchair occupant restraints should not be held away from the body by wheelchair components such as armrests or wheels.

Keep belts clear of sharp objects. Do not alter belts. Do not interchange belts from one position to another. Keep the supplied belts together as a complete set.

**Belt and Track Maintenance:** Inspect belt assemblies frequently. Any defects such as belt cuts, fraying or malfunctioning call for replacement of the entire belt assembly. “L” track must be clean and not worn, bent or otherwise damaged (prohibiting proper belt attachment). If there is any sign of damage, wear, abnormal condition or improper operation of belts, belt hardware (hooks, keepers, latch plate, receptacle), or track, discontinue use and replace components immediately.

Severe conditions (weather, environment, heavy usage, etc.) may require more frequent inspections. Exposure to severe conditions will dramatically reduce the life of the system.

## WHEELCHAIR AND OCCUPANT RESTRAINT

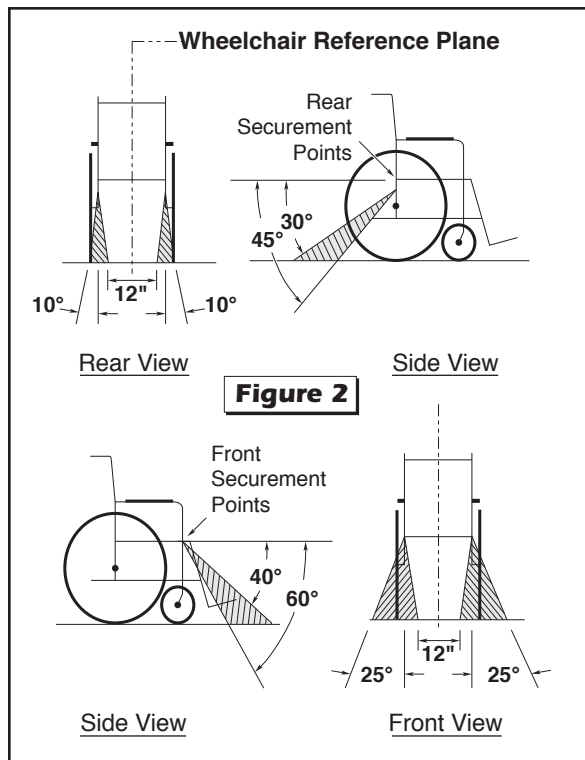

### Restraint Belt Angles

Locate wheelchair in forward-facing position centering wheelchair squarely within “L” track. The front and rear belts, when attached, should create angles approximately as shown in Figure 2. Preferred angles and locations of belts from wheelchair securement points to vehicle anchor points are shown. Front tie-downs should be angled out far for lateral stability when possible. **Note:** These are optimum angles and cannot be achieved in some cases.

### Keeper Fitting and “L” Track Attachment Instructions

The belts supplied in the Forward-Facing Wheelchair and Occupant Belt/Track System are equipped with keeper fittings (attachments) which engage the “L” track. Engage and release the keeper fittings as detailed and shown on the following page. **Note:** Refer to pages 32 and 33 for belt attachment and release procedures.

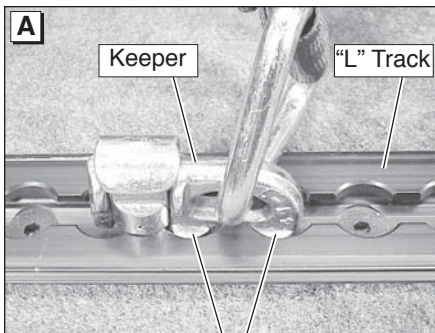

Align engagement feet with holes.

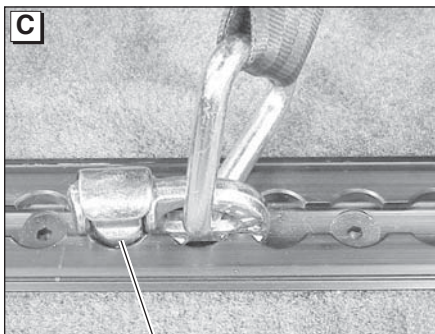

Fully-engaged Keeper

## Keeper Fitting and “L” Track Attachment Instructions

### To Engage Keeper Fitting:

1. Insert keeper fitting into track (align two engagement feet with holes in track). See Photo A.
2. Push down on fitting and slide fitting 1/2 slot in either direction until it clicks and locks in position (see Photos B and C). Pull firmly on belt to ensure fitting is locked in track.

### To Release Keeper Fitting:

1. Lift plunger and slide fitting 1/2 slot in either direction and lift fitting out of track.

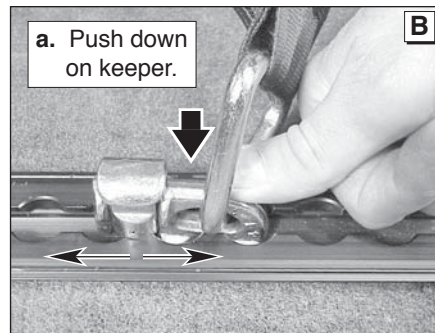

2. Slide keeper 1/2 slot in either direction.

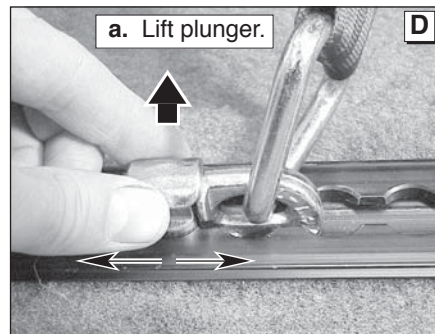

2. Slide keeper and lift.

# WHEELCHAIR AND OCCUPANT RESTRAINT

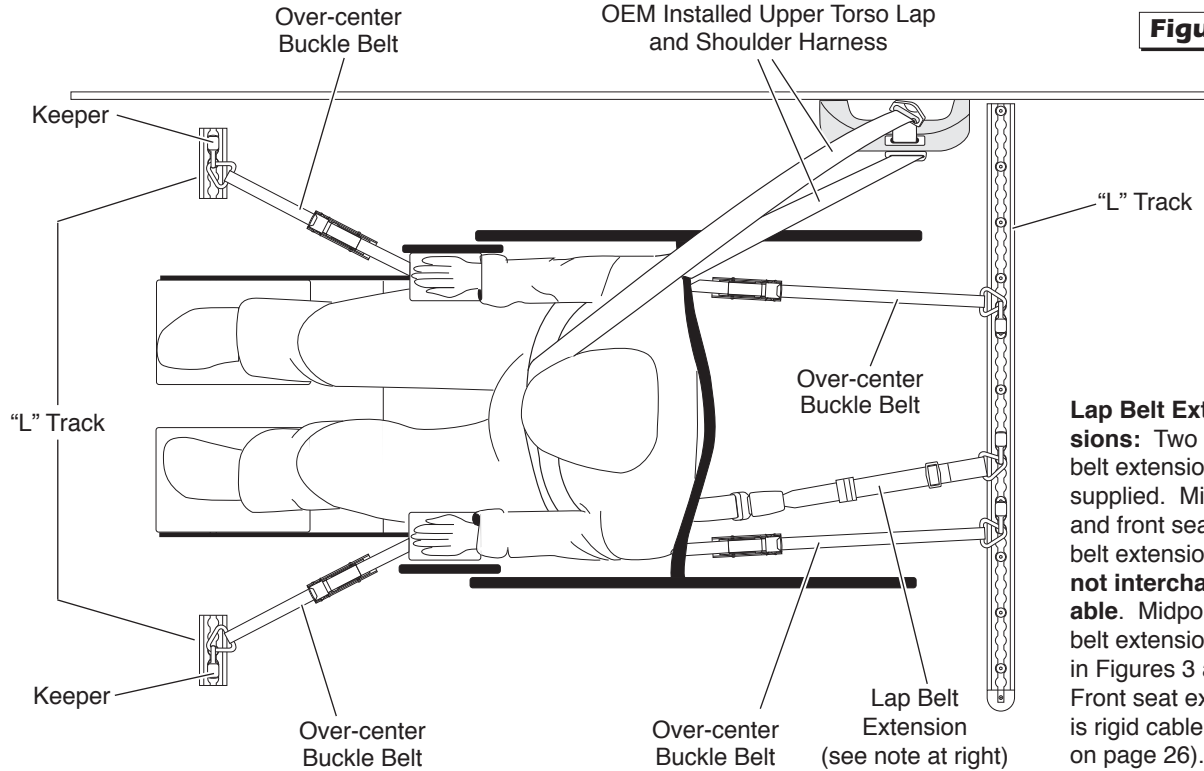

**Figure 3**

**Lap Belt Extensions:** Two lap belt extensions are supplied. Midpoint and front seat lap belt extensions are **not interchangeable**. Midpoint lap belt extension shown in Figures 3 and 4. Front seat extension is rigid cable (shown on page 26).



# WHEELCHAIR AND OCCUPANT RESTRAINT

**Note:** Generic seat position shown. Attachment procedures are identical for all positions. Photos on pages 32 and 33 depict securement of wheelchair in midpoint position.

Keeper attachment details are provided on page 29.

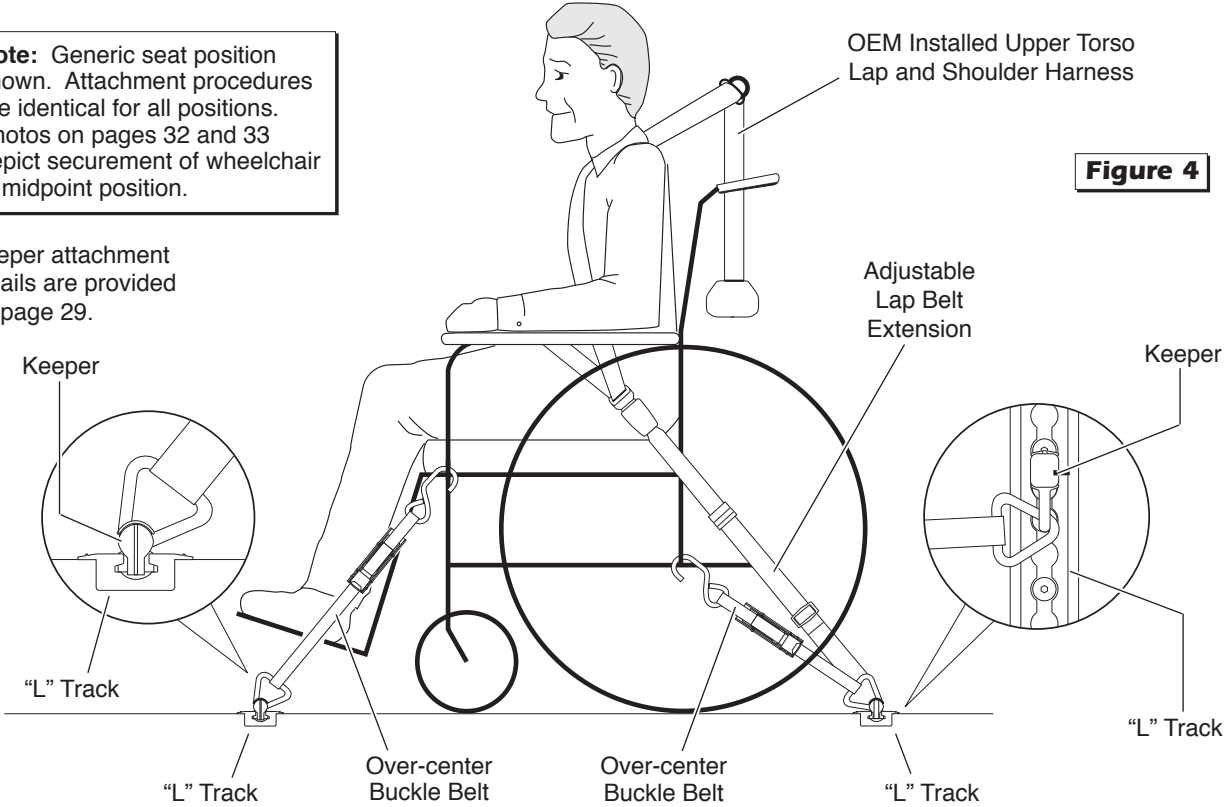
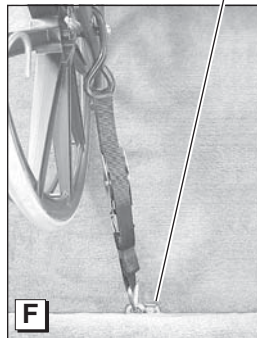

**Figure 4**

## WHEELCHAIR AND OCCUPANT RESTRAINT



Hook  
Keeper



### Over-Center Belt Attachments

◀ 1. Connect chair hook to a solid frame member of the wheelchair (as shown in Photo E).

2. Position and connect belt keeper fitting (attachment) to appropriate track anchorage point (slots). Attach keeper as detailed on page 29.

Pull firmly on belt to ensure fitting is locked in track.

**Note:** Belt angles should be as shown in Figure 2 on page 28.

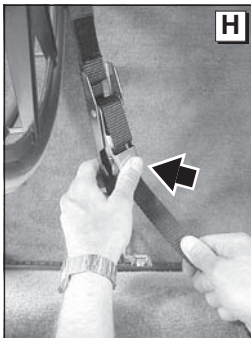
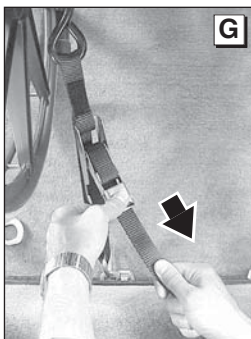

3. With buckle open, pull loose end of belt until tight (see Photo G). While holding the loose end with one hand, close the lever of the clamp (buckle) down until it locks. See Photo H.

4. Connect Velcro™ ▶

Repeat procedures for all belts.

**Note:** Check to see that front and rear belts are tight and the chair is secure enough that it does not have any movement. Lock wheelchair brakes.

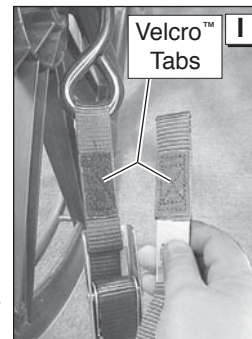

**Belt Release:** Press lever clamp (lock) to release tension on belt.





Extension Belt

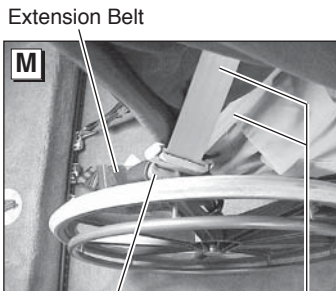

Extension Belt

Receptacle

Chrysler Lap and Shoulder Belt

### Lap and Shoulder Belt Attachments

Refer to Photos K-N.

1. Position and connect the adjustable lap belt extension keeper fitting (attachment) to appropriate track anchorage point (slots). Attach keeper as detailed on page 29. Pull firmly on belt to ensure fitting is locked in track.
2. Connect the lap and shoulder belt to the lap belt extension (insert latch plate in female receptacle). Position the upper torso (shoulder) belt across the center of the shoulder. Position the lap belt low across the front of the pelvis (near hip). See Photos K-N.

Wheelchair occupant restraints should not be held away from the body by wheelchair components such as wheelchair armrests or wheels.

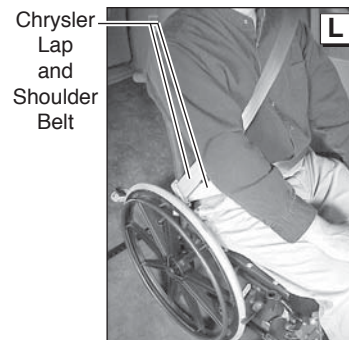

Chrysler Lap and Shoulder Belt

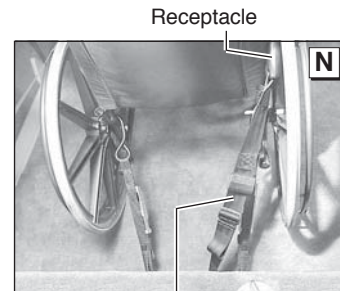

Receptacle

Extension Belt

## SEAT REMOVAL AND INSTALLATION

**Front Seats:** In an effort to produce vehicles that can be configured to meet a variety of customer needs, the driver and passenger seat bases have been designed so they may be removed. This feature allows the owner and sales representative to determine the appropriate seating arrangement to accom-

modate owner needs. Once the desired seat arrangement is determined, all power seat electrical harnesses must be reconnected to the appropriate fixed seat positions.

Driver's and passenger's side front seats are equipped with "step & roll" quick-release seat base attachments that engage recessed floor strikers (supports). The "step & roll" quick-release front seat is installed and removed as detailed on pages 40-43 of this manual.

**Power Seats:** Entervan front seats are equipped with electrical wiring harnesses to accommodate optional equipment such as heated seats, air bags, etc. **Before removing seats, be certain all seat electrical harnesses are disconnected.**

When seats are removed, the seat electrical harness **plug must be connected to the receptacle** provided at the top of the seat base. See Photos B and D on page 37 of this manual.

**Adjustable Pedals:** The adjustable brake and accelerator pedal feature is disabled when the driver seat is removed.

### **WARNING**

**Park vehicle and turn engine off before removing or installing seats. Failure to do so may result in serious bodily injury and/or property damage.**

### **CAUTION**

**Disconnect seat wiring harness before removing seat. Failure to do so may result in property damage.**

When positioning seats, it is **your responsibility** to reconnect all seat electrical harnesses. Failure to properly connect power seat electrical harnesses may result in power seat functions being disabled and/or the air bag light illuminating.

Entervan front seats are equipped with an exclusive “step & roll” quick-release system. Refer to the seat removal and installation instructions provided in this manual. **Note:** Driver and passenger side front seats **are not interchangeable**.

Contact your sales representative or call The Braun Corporation at 1-800-THE LIFT if any of this information is not understood.

### Seat Base Rear Covers

Entervan front seats are equipped with easy to remove rear seat base covers. The covers must be removed when removing and installing seats. Refer to photo at right. Simply pull back on the covers to remove them (Velcro® secured). Align and push covers into position when reinstalling seats.

**Caution: Do not contact and damage** the seat base electrical harness when removing and installing the rear seat base covers.

Pull back on Rear Seat Cover

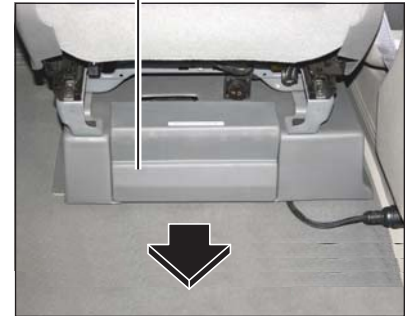

**BLANK for LAYOUT**



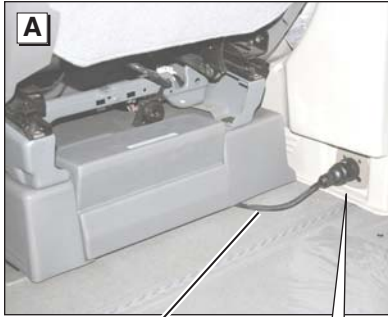

Seat  
Harness

### Front Seat Wiring Harnesses and Receptacles

An electrical harness receptacle is located to the rear of each seat base in the wall (at "B" pillar). The seat wiring harness plug connects to the receptacle socket (screw-on connector details on pages 38 and 39 of this manual).

**Before removing seats, be certain seat wiring harnesses are disconnected.**

When seats are removed, the **seat electrical harness plug must be connected to the receptacle** provided in the seat base. See Photos B and D.

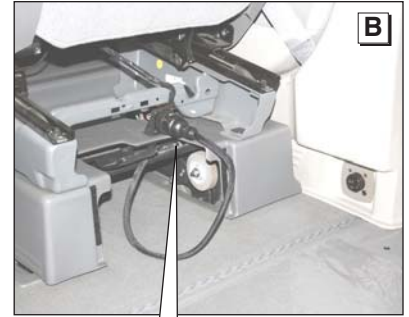

Seat  
Plug



B-Pillar  
Receptacle



Seat Storage  
Receptacle

### ⚠ CAUTION

Disconnect seat wiring harness before removing seat. Failure to do so may result in property damage.

### ⚠ WARNING

Connect front seat wiring harness plug to socket provided at top of seat base before removing front seat. Failure to do so may result in serious bodily injury and/or property damage.

When installing seats, **be certain seat wiring harnesses are reconnected.** Failure to do so may result in power seat functions being disabled and/or the air bag light illuminating.

**Adjustable Pedals:** The adjustable brake and accelerator pedal feature is disabled when the driver seat is removed.

#### Screw-on Connectors

Front seat wiring harnesses are equipped with a screw-on connector (plug). Operate connectors as detailed here and on page 39.

A label is posted on the seat wiring harness plug which identifies the top of the connector (“TOP” decal 28891). Position the plug with the “TOP” label facing up when con-

necting the plug to either receptacle socket. Use this feature as an alignment guide.

**Note:** Alignment grooves (slots) are provided in receptacle sockets. Receptacle sockets have a single wider alignment groove that is positioned at 12 o’clock (shown on page 39). Seat wiring harness plugs are equipped with mating alignment guides (ears).



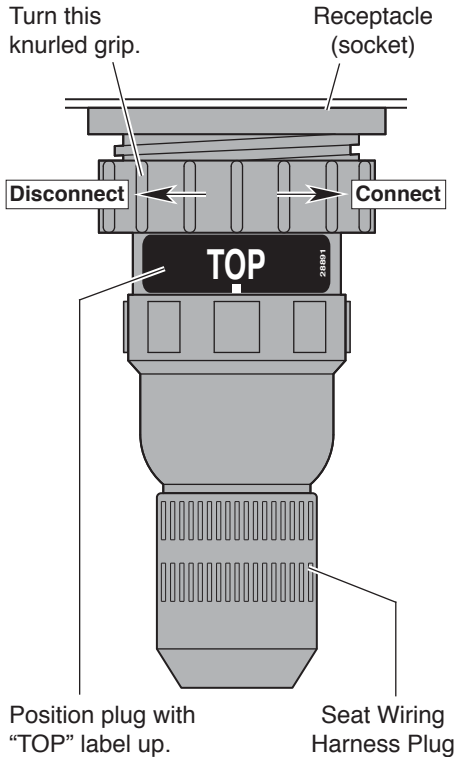

## Screw-on Connectors

**To Connect:** Align the seat harness connector by positioning the plug with the "TOP" label facing up. Align the seat harness connector alignment guides with the receptacle socket alignment grooves (will only connect one way).

**Carefully** insert the seat harness plug in the receptacle socket. Turn seat harness connector large diameter knurled grip clockwise fully (turn gripper nearest to socket).

**To Disconnect:** Turn seat harness connector large diameter knurled grip counterclockwise and disengage connectors.

Alignment Groove  
(at 12 o'clock)

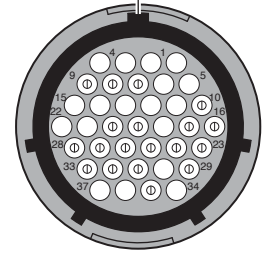

Receptacle Socket

Alignment Guide

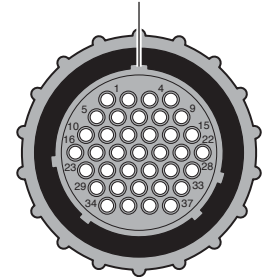

Seat Harness Plug

## SEAT REMOVAL AND INSTALLATION

### Front Seat Bases

“Step & roll” quick-release seat base attachments engage recessed floor strikers (supports). A foot-activated release pedal is located at the rear of the seat base. Stepping on the pedal disengages the attachments and deploys the seat base rear wheels.

**Note:** For ease of disengagement, move the seat to the full forward and upright position before removing seat(s). Push the seat back forward and upward while stepping on foot pedal (ensures full deployment of rear wheels).



Push seat back forward and upward while stepping on foot pedal.

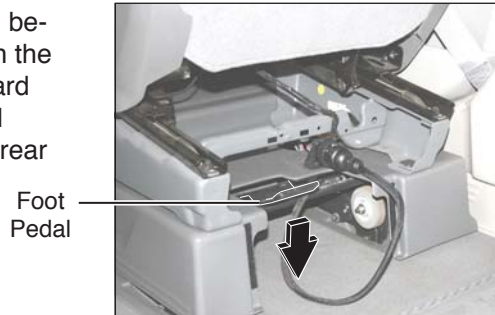

### Front Seat Removal Instructions

1. Move seat to full forward and upright position.
2. **Caution! Disconnect seat wiring harness before removing a front seat base.** Connect harness to seat base socket. See page 37-39 for wiring harness details.
3. Depress foot pedal (push down). **Note:** Push seat back forward and upward while stepping on foot pedal. See Photos and Figures A-D.
4. Pull up and back on the rear of seat (deploy front wheels). See Figures E and F.
5. Roll seat base out of vehicle as shown.

## SEAT REMOVAL AND INSTALLATION

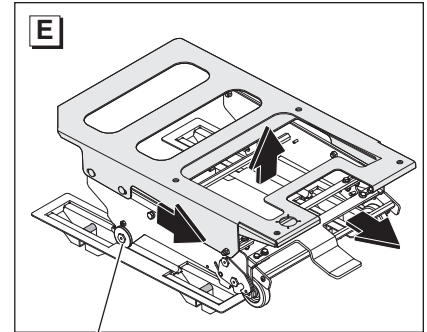
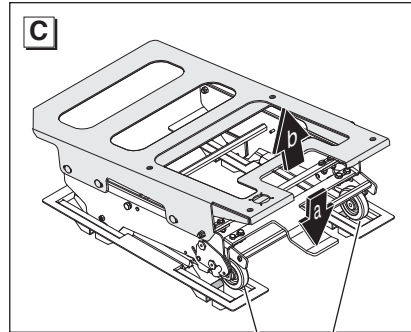
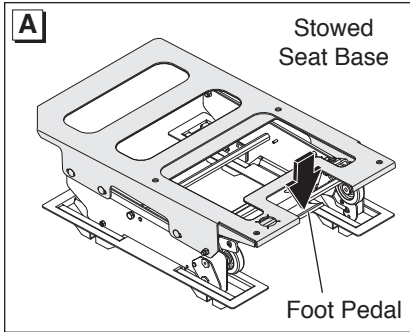

Deployed Rear Wheels

Deployed Front Wheels

Illustrations depict seat base only.

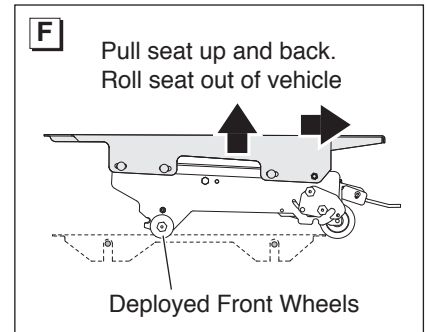
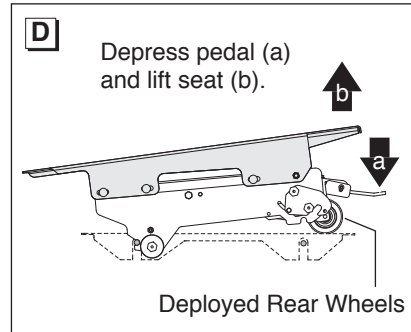
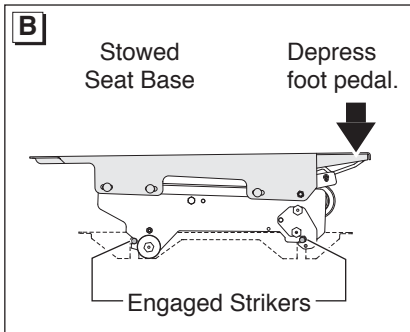

## SEAT REMOVAL AND INSTALLATION

### Front Seat Bases

“Step & roll” quick-release seat base attachments engage recessed floor strikers (supports). A foot-activated release pedal is located at the rear of the seat base. A cross bar is positioned directly under the pedal. Stepping on the bar engages the rear seat base attachments to lock the seat base.

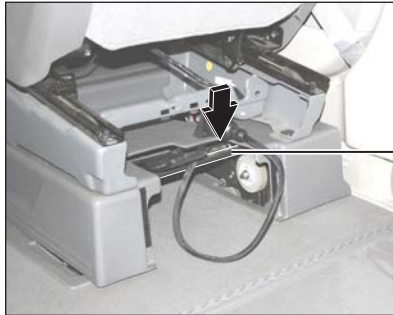

### Front Seat Installation Instructions

1. Roll seat base into position, just behind the floor mounted strikers. See Figures A and B. Move seat base forward to engage front strikers. See Figures C and D.

**Note:** Position outside of seat base alongside wall panel for easy alignment.

2. Depress rear cross bar (push down) to stow rear wheels and engage rear seat attachments with floor strikers. See Figures C-F. Lift seat to **ensure** floor strikers are **locked** in seat attachments.
3. Connect (plug) seat electrical harness to B-pillar receptacle. See page 37.

## SEAT REMOVAL AND INSTALLATION

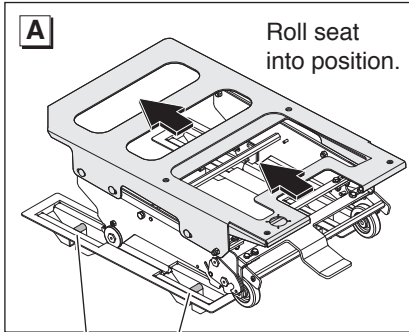

Floor Strikers

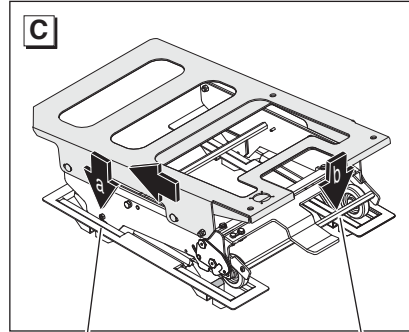

Engaged Front Strikers      Engagement Bar

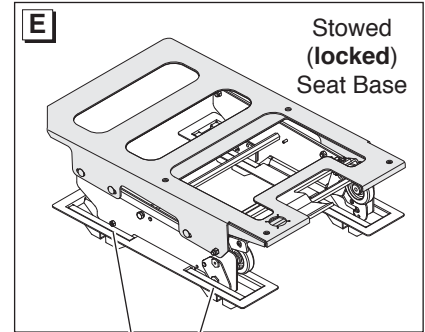

Engaged Strikers

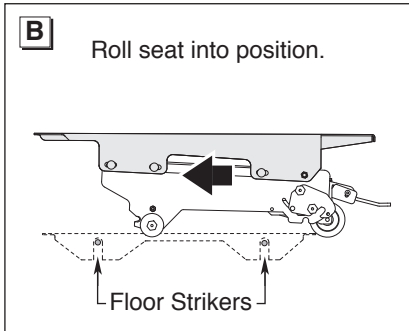

Floor Strikers

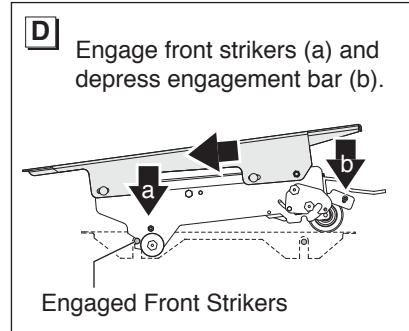

Engaged Front Strikers

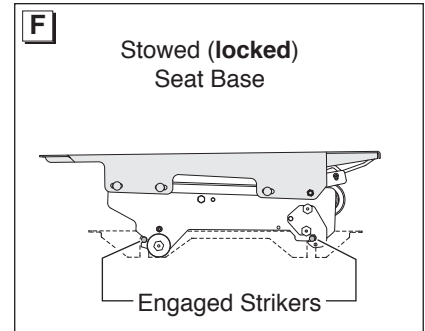

Engaged Strikers

## SEAT REMOVAL AND INSTALLATION

### Third Row Seats

Third row 60/40 split bench seats have been modified during conversion procedures. Seat backs can be folded down to the flat position and tipped forward to provide full access to rear floor storage compartments. The Stow 'n Go (stow in floor) feature is **not available**.

Seat removal is allowed for the driver side section of the seat (instructions on opposite page). The electronic control module assembly is mounted under the passenger side section of the seat. Removal of the passenger side section of the seat is **prohibited\***.

\* Should removal of the passenger side section of the third row seat be imperative, contact The Braun Corporation at 1-800-THE LIFT®. A Braun Product Support representative will direct you to an authorized service technician.

### Folding (tipping) Third Row Seats

Seat backs can be folded down to the flat position and tipped forward. Seats **must be returned to the full stowed (locked) position before driving**.

#### To Fold (tip forward) Third Row Seats

1. From the rear of the vehicle, fold down the back of the bench seat (pull release strap #1).
2. Pull the release strap at the rear of the seat (between seat base and floor), and lift and fold (tip) the seat forward.

#### To Unfold (rotate rearward) Third Row Seats

**Carefully** (slowly) rotate and lower seat rearward to stowed position. **Ensure** the rear spring-loaded at-

tachments engage floor strikers. Raise the seat back (pull release strap #1) and attempt to move seat back and forth.

**Caution:** Use extra care when lowering passenger side section of seat. **Do not** slam seat down or allow seat to drop (free-fall). Doing so may result in damage to the electronic control module assembly.



## SEAT REMOVAL AND INSTALLATION

### Third Row Seat Removal:

**Note:** Removal of the passenger side section of the seat is **prohibited\***. Policy detailed on previous page.

1. From the rear of the vehicle, fold down the back of the bench seat (pull release strap #1).
2. Pull the release strap at the rear of the seat (between seat base and floor), and lift and fold (tip) the seat forward. **Note:** Push top of linkage rod forward to stabilize seat (over center position)
3. Remove the bolt securing the linkage arm to the floor-mounted bracket.
4. Remove E-ring retaining clips from the pivot pins securing the front floor mounts.
5. Remove the pivot pins.
6. **Carefully** remove seat.

### Third Row Seat Installation:

Reverse removal procedures.

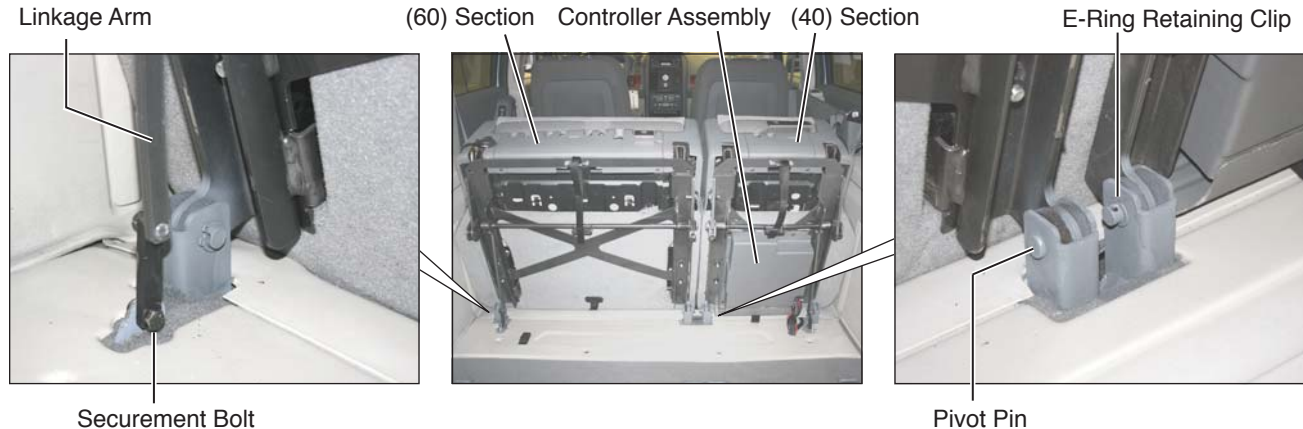

## LIMITED WARRANTY

□ In accordance with the Chrysler 5 year/100,000 mile corrosion warranty, The Braun Corporation warrants to the purchaser of its Entervan conversion that it will repair (or replace at Braun's sole option) any defect in material or factory workmanship in the metal fabrication on or of the frame, floor and lowered door extension for a period of 5 years or 100,000 miles on the odometer, whichever occurs first. The Braun Corporation further warrants to the purchaser that it will

repair (or replace at Braun's sole option) any defect in material or factory workmanship for the remainder of the modifications and alterations for associated parts for a period of 36 months or 36,000 miles, whichever occurs first. For clarification purposes, the following chart outlines The Braun Corporation Entervan warranty coverage. Refer to your Chrysler warranty information booklet for all Chrysler OEM (factory) limited warranty details.

Years/Miles in Service	Specific Area Covered
<p><b>36 Months</b> or <b>36,000 Miles</b> (whichever comes first)</p>	<p>Entervan frame and floor structural components</p> <p>Entervan ramp, door and associated structural components</p> <p>Entervan electrical components including but not limited to switches, wires, connectors and the controller</p> <p>Entervan electromechanical kneel systems including but not limited to electric actuator, chain, pulleys and associated hardware</p>



<b>Years/Miles in Service</b>	<b>Specific Area Covered</b>
<p><b>36 Months</b> or <b>36,000 Miles</b> (whichever comes first)</p>	<p>Entervan appearance items including but not limited to interior floor covering and slide door lowered extension assemblies.</p>
<p><b>Corrosion Limited Warranty</b></p> <p><b>Outer Panels</b></p> <p><b>5 Year or 100,000 Miles</b> (whichever comes first)</p> <p><b>All Panels</b> (Exceptions)</p> <p><b>3 Years/Unlimited Miles</b></p>	<p><b>Corrosion Limited Warranty:</b></p> <p><b>Outer Panels:</b> Entervan frame, floor and lower door modification metal fabrication corrosion applies to perforation only. Entervan lower slide door modification corrosion applies to outer-body sheet metal and paint. Perforation is a rust-through condition such as an actual hole in the metal.</p> <p><b>All Panels (Exceptions):</b> Cosmetic or surface corrosion (resulting from stone chips for example) would not be covered or repaired under this coverage. If corrosion does not cause holes, and is not the result of usage and/or environmental conditions, repair coverage lasts for 3 years/unlimited miles.</p>

## LIMITED WARRANTY

Both the 5 year/100,000 mile corrosion and the 3 year/36,000 mile limited warranties described on previous page commence on the date the conversion is put into service, providing the warranty registration card is completed and received by The Braun Corporation within thirty days of the purchase.

The Braun Corporation agrees to repair or replace any of its Entervan factory-installed parts found to be defective within the appropriate warranty period or mileage. This limited warranty also covers the cost of labor for the repair or replacement of said parts for three years provided that the repair is authorized by The Braun Corporation and carried out by an authorized service establishment (a Braun labor schedule determines the cost allowance for repairs). The Braun Corporation will not honor any warranty claim for repairs or replacement of parts unless the claim is submitted with the appropriate factory warranty authorization data and the repairs or replacement of the parts are completed by a factory-authorized repairman. The factory authorization data, together with the name and location of the fac-

tory-authorized repairman, can be obtained by either written or telephone contact with The Braun Corporation at the addresses appearing in this manual.

The return authorization procedure must be adhered to in order to process any warranty and repair claims (details on following page).

The Braun Corporation reserves the right to designate where any warranty work is to be performed.

The Braun Corporation also reserves the right to examine any defective workmanship or part prior to any authorization of necessary repairs. This Entervan limited warranty is not intended to replace or substitute any other warranties issued by the original manufacturer of the vehicle or other suppliers of components. This limited warranty shall not apply to any part or workmanship that may become defective due to misuse, neglect, accident or other casualty, modifications or alterations or unauthorized repairs. Further, this limited warranty shall not extend to parts or workmanship that may become defective because

of the failure of anyone to operate the same in accordance with the printed instructions of The Braun Corporation or because of operation of the same beyond its capacity.

This limited warranty does not cover normal maintenance, service, or periodic adjustments necessitated by use or wear.

Second buyers of a Braun Entervan conversion may transfer the remaining warranty, if any, by obtaining a transfer of warranty application from The Braun Corporation. This application must be returned to The Braun Corporation within thirty days from the date you purchase the vehicle and proof of the date of purchasing must be supplied with the transfer of warranty application. There will be a minimum warranty transfer fee.

**The Braun Corporation shall not be liable for any incidental or consequential damages resulting from any breach of warranty.**

The Braun Corporation shall not be liable for towing charges, travel and lodging, or any other expense incurred due to the loss of use of vehicle or other reason.

**To the extent any implied warranties exist by operation of federal or state law, such implied warranties are limited in duration to the period of the express limited warranty herein.**

### Return Authorization Procedure

When processing any warranty claims (parts, repairs, etc.), all requests must be processed through the Braun Corporation Product Support Department. Call 1-800-THE LIFT® during working hours. Product Support will issue a Return Material Authorization (RMA) number and detail the procedures required for processing returns and/or authorizing credit.

The last eight digits of the vehicle identification number (VIN) **must be provided when filing a warranty claim or ordering parts.**

## PREVENTIVE MAINTENANCE

Maintenance is necessary to ensure safe and trouble free Entervan operation. General preventive maintenance consisting of inspections of your Entervan systems along with cleaning and lubricating procedures should be a part of your routine (lubrication requirements are minimal). Keeping the passenger slide door lower track pan free of debris, ice and snow is one of the most effective preventive maintenance practices to exercise. Regular preventive maintenance procedures will increase the service life of the Entervan, as well as enhancing safety.

During routine inspections, operate all Entervan systems and note the following (as equipped):

- Is the power source adequate or weak?

- Does the electronic control system function properly?
- Do the control switches function properly?
- Does the kneel feature function properly?
- Does the power door function properly?
- Does the ramp deploy and stow properly?
- Inspect wheelchair and occupant restraint belts, buckles and hardware for damage, wear, abnormal condition or improper operation.

Entervan ramps are equipped with sealed bearings and Teflon™ bushings to decrease wear, provide smooth operation and extend the service life of the ramp. A “dri-film” style of light oil should be applied to the ramp inboard pivot points and outboard ramp

extension hinge (goes on wet then dries). Lubricants of this type are available that do not attract dust or debris. Clean the components and the surrounding area before applying lubricants. Use of improper lubricants can attract dirt or other contaminants which could result in wear or damage to components.

Inspect and clean as detailed frequently and routinely (minimum four weeks or 100 cycle intervals). Lubricate the ramp as specified approximately every three months.

**Note:** These intervals are a general guideline and will vary according to frequency of use and conditions. Exposure to severe conditions (weather, environment, heavy usage, etc.) may require inspection and maintenance procedures to be performed more often.

Preventive maintenance visual inspections, cleaning and lubrication procedures **do not** take the place of the procedures specified in the Maintenance and Lubrication Schedule provided in the Entervan service manual. The procedures outlined in the Maintenance and Lubrication Schedule **must be performed at the recommended scheduled intervals by an authorized Braun Corporation service representative who has attended and been certified by The Braun Corporation Sales and Service School.**

If there is any sign of damage, wear, abnormal condition or improper operation, **discontinue Entervan use immediately.** Contact your sales representative or call The Braun Corporation at 1-800-THE LIFT. One of our Product Support representatives will direct you to an authorized service technician who will inspect your Entervan.

**⚠ WARNING**

**Maintenance and lubrication procedures must be performed by authorized service personnel as specified in the applicable Entervan service manual. Failure to do so may result in serious bodily injury and/or property damage.**

## AUXILIARY POWER SUPPLY / BELOW FLOOR OBSTRUCTIONS

**Note:** The technical information provided on pages 52-55 of this manual is service related. If you are having an electrical tie-down, power seat or other auxiliary electrical device installed in your Entervan, this information should be supplied to the technician. Otherwise, disregard this section.

### **⚠ CAUTION**

**Do not connect auxiliary devices to vehicle battery. Doing so may result in damage to electrical system and/or electronic components.**

**Auxiliary Power Supply: Do not** connect auxiliary devices directly to the vehicle battery. Doing so **may result in damage to electrical system and/or electronic components.**

Two fuse blocks are provided as an auxiliary power source for dealer-installed auxiliary electrical device(s). Fuse block details and specifications are provided on page 53. The fuse blocks are located in the bottom of the center dash console.

### **Below Floor Obstructions:**

When installing aftermarket equipment in an Entervan, obstructions below the floor must be avoided. Obstructions include wiring, fuel system, brake lines, etc. Installers must be aware of these obstructions.

Refer to the illustration on page 55 to avoid contacting or damaging vital components under the floor.

### **⚠ WARNING**



**Risk of electrical fire!  
Install and electrically terminate auxiliary electrical device as specified by device manufacturer.**

## AUXILIARY POWER SUPPLY / BELOW FLOOR OBSTRUCTIONS

**Fuse Blocks:** Two fuse blocks are provided for use as an auxiliary power source (one **Ignition** fuse block and one **Battery** fuse block).

The Battery fuse block provides power at all times (independent of the vehicle ignition). The Ignition fuse block supplies power **only** when the vehicle ignition is on.

The **installer is responsible** for supplying the correct gauge wire and fuse for the particular device to be attached to the fuse block (**as specified** by the manufacturer of the device).

**Ignition Fuse Block:** The total maximum load must not exceed **40 amperes**.

**Battery Fuse Block:** The total maximum load must not exceed **40 amperes**.

**Note:** If installing an auxiliary electrical device that requires more than a **40 ampere** power source, **an alternative power source must be provided**.

**Fuse Block Access:** The fuse blocks are located at the bottom of the center console. Remove upper console panel (3 fasteners per side). Remove lower panel.

**Note:** The fuse blocks are part of the gateway electrical assembly. Two grounding studs are also provided.

Under Dash Fuse Blocks

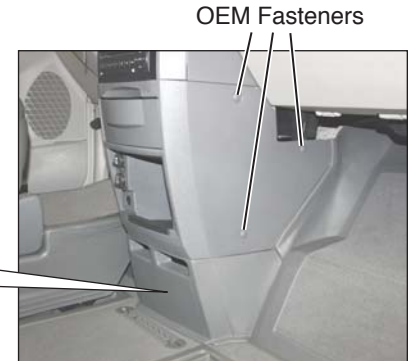
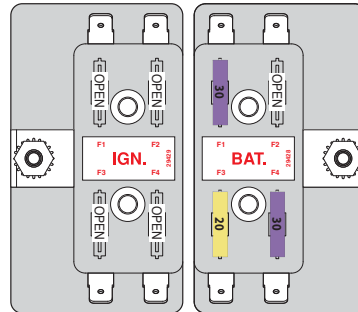

## AUXILIARY POWER SUPPLY / BELOW FLOOR OBSTRUCTIONS

### Below Floor Obstructions

When installing an electrical tie-down, power seat or other auxiliary electrical device in an Entervan, obstructions below the floor must be avoided. Obstructions include wiring, fuel system, brake lines, etc. Installers must be aware of these obstructions.

#### **WARNING**

**Check for obstructions such as wires, gas lines, exhaust, etc. before drilling or cutting through floor. Failure to do so may result in serious bodily injury and/or property damage.**

Refer to the illustration on the following page when installing aftermarket equipment to avoid contacting or damaging vital components under the floor. **Drilling or cutting into such obstructions may result in potential hazards as well as property damage.**

**Note:** Some wiring harnesses shown may not be present. Avoid all harness locations.

#### **WARNING**



**Risk of electrical fire! Install and electrically terminate auxiliary electrical device as specified by device manufacturer.**



# AUXILIARY POWER SUPPLY / BELOW FLOOR OBSTRUCTIONS

## Below Floor Obstructions

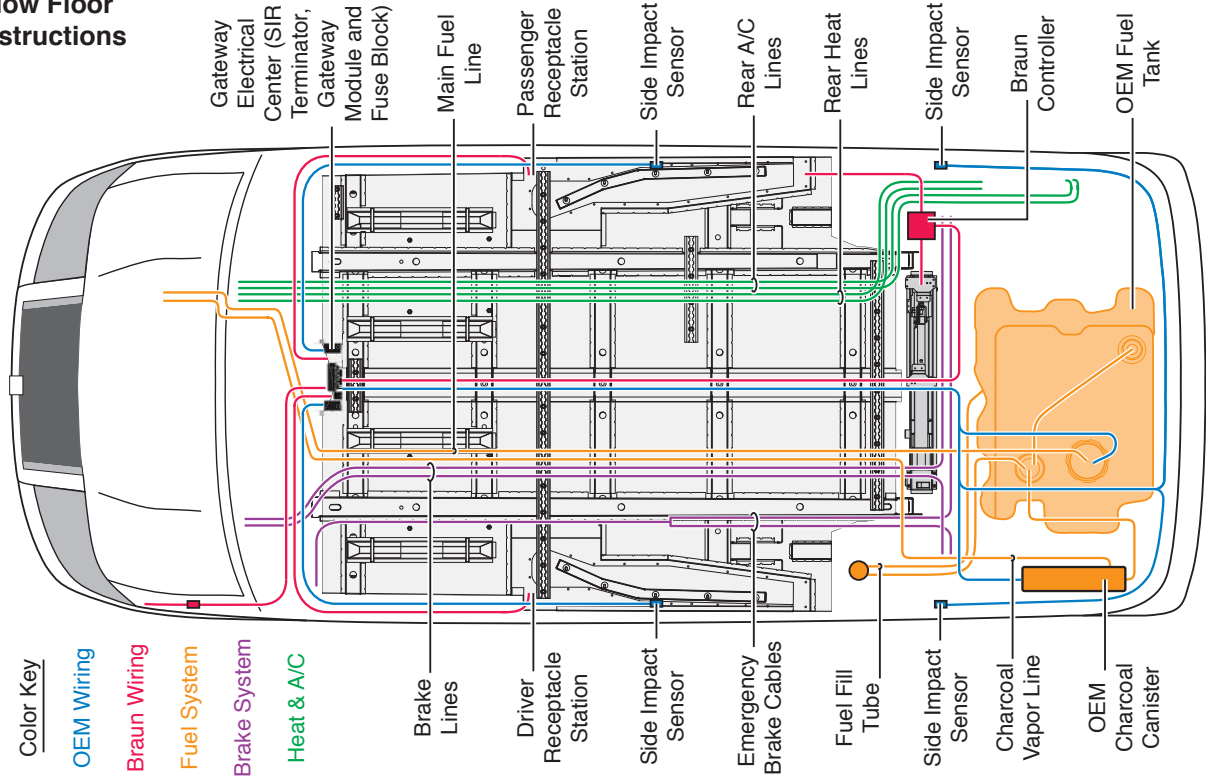

## JACKING AND TIRE CHANGING INSTRUCTIONS

### Jacking and Tire Changing

**Interior Spare Tire Mount:** The spare tire is located behind the rear bench seat in the passenger side floor compartment. The OEM jack, jack handle and winch handle tools are stored inside the rear driver side wall compartment (OEM location).

**Jack Points:** Front and rear wheel jacking points have been repositioned during conversion procedures. The modified vehicle jack points are depicted in the illustration at right.

**Jacking and Tire Changing Procedures:** Jacking and tire changing procedures have not been affected by the conversion. If the rear of the vehicle is in the kneeled position, raise the rear of the vehicle to normal position before jacking. Detailed tire changing instructions are provided in the OEM-supplied owner's manual.

Refer to the OEM-supplied manual for tire changing instructions and safety precautions, as well as instructions regarding other roadside emergencies.

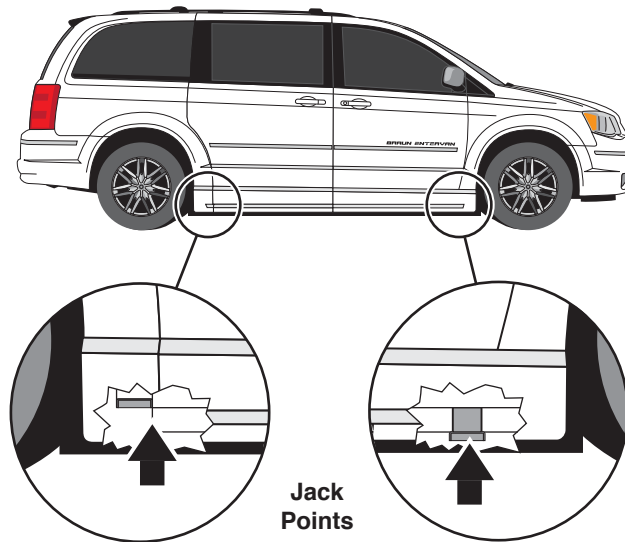

**Reporting Safety Defects to the  
United States Government**

If you believe that your vehicle has a defect which could cause a crash or could cause injury or death, you should immediately inform the National Highway Traffic Safety Administration (NHTSA) in addition to notifying the Braun Corporation.

If NHTSA receives similar complaints, it may open an investigation, and if it finds that a safety defect exists in a group of vehicles, it may order a recall and remedy campaign. However, NHTSA cannot become involved in individual problems between you, your dealer or the Braun Corporation.

To contact NHTSA, you may either call the Auto Safety Hotline toll-free at 1-800-424-9393 (or 366-0123 in Washington, D.C. area) or write to:

NHTSA, U.S. Department of Transportation  
Washington, D.C. 20590

You can also obtain other information about motor vehicle safety from the Hotline.

**Reporting Safety Defects to The  
Braun Corporation**

In addition to notifying NHTSA we certainly hope you will notify us. Please call us at 1-800-THE-LIFT®, or write:

The Braun Corporation  
631 West 11th Street  
P.O. Box 310  
Winamac, IN 46996 USA

## TOWING

---

### Towing with a Entervan

Use of this lowered floor conversion vehicle for towing is **prohibited**.

### If your Entervan Needs Towed

If case of service, The Braun Corporation recommends that this lowered floor conversion vehicle be transported on a trailer rather than towed with one set of wheels suspended and the other set of wheels remaining in road contact.



**"Providing Access to the World"®**



**Over 300 Braun  
Dealers Worldwide**



Life is...  
Challenges, and how  
you overcome them.  
Bob W. Brown

34443

March 2008

Patent #6,825,628 B2

 **BraunAbility™**

 **THE BRAUN  
CORPORATION**